

MINI ASSEMBLAGE P.U.D. PLAT EIGHT

ALSO KNOWN AS GREYSTONE P.U.D.

BEING A REPLAT OF A PORTION OF TRACTS 73, 74, 75, 76, 85, 86, 87, AND 88, BLOCK 55, PALM BEACH FARMS COMPANY PLAT NO. 3, RECORDED IN PLAT BOOK 2, PAGES 45 THROUGH 54, PUBLIC RECORDS OF PALM BEACH COUNTY FLORIDA, BEING IN SECTION 28, TOWNSHIP 45 SOUTH, RANGE 42 EAST PALM BEACH COUNTY, STATE OF FLORIDA

OCTOBER 2006 SHEET 5 OF 5

This Instrument Prepared By:
Kevin M. Beck, P.S.M.
Certificate of Authorization No. LB 6781
OCTOBER 2006

Cabin, Glendon & Associates, Inc.
Engineers Surveyors Planners
580 Village Boulevard, Suite 340
West Palm Beach, Florida 33409
Phone: 561.864.8161 Fax: 561.864.8380

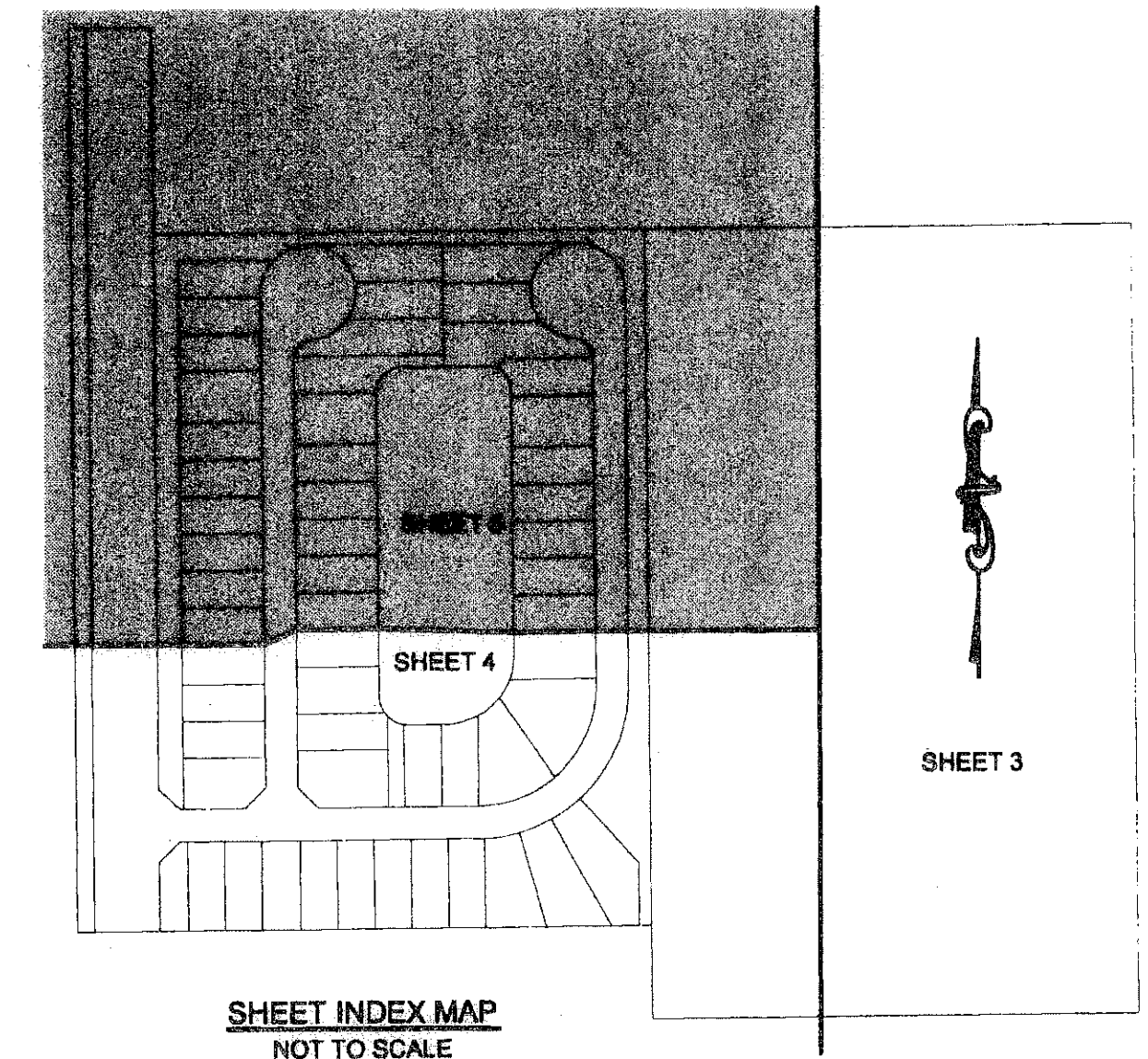
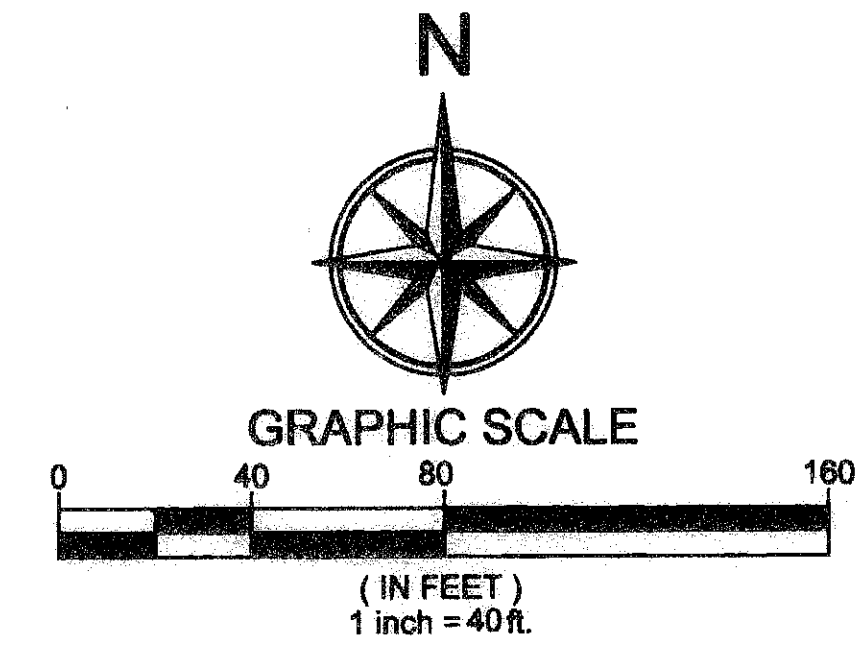

SHEET INDEX MAP
NOT TO SCALE

- LEGEND:**
- BE = BUFFER EASEMENT
 - CA = CENTRAL (DELTA) ANGLE
 - CH = CHORD
 - DB = DEED BOOK
 - DE = DRAINAGE EASEMENT
 - ESMT = EASEMENT
 - L = ARC LENGTH
 - LAE = LIMITED ACCESS EASEMENT
 - LMAE = LAKE MAINTENANCE ACCESS EASEMENT
 - LME = LAKE MAINTENANCE EASEMENT
 - LWDD = LAKE WORTH DRAINAGE DISTRICT
 - OE = OVERHANG EASEMENT
 - ORB = OFFICIAL RECORDS BOOK
 - PB = PLAT BOOK
 - PBCUE = PALM BEACH COUNTY UTILITY EASEMENT
 - POB = POINT OF BEGINNING
 - POC = POINT OF COMMENCEMENT
 - PRM = PERMANENT REFERENCE MONUMENT
 - P.U.D. = PLANNED UNIT DEVELOPMENT
 - PG(S) = PAGE(S)
 - (R) = RADIAL
 - R,D&D = ROAD, DIKE AND DITCH RESERVATION
 - R/W = RIGHT-OF-WAY
 - UE = UTILITY EASEMENT
 - C/L = CENTERLINE
 - ⊕ = CENTERLINE
 - = PERMANENT REFERENCE MONUMENT (4" X 4" CONCRETE MONUMENT WITH A 2" ALUMINUM PLATE STAMPED "LB 6791", UNLESS OTHERWISE NOTED)
 - ▼ = ZERO LOT LINE SYMBOL
 - = PERMANENT CONTROL POINT (SET "PK" NAIL AND DISK LABELED "LB 6791")

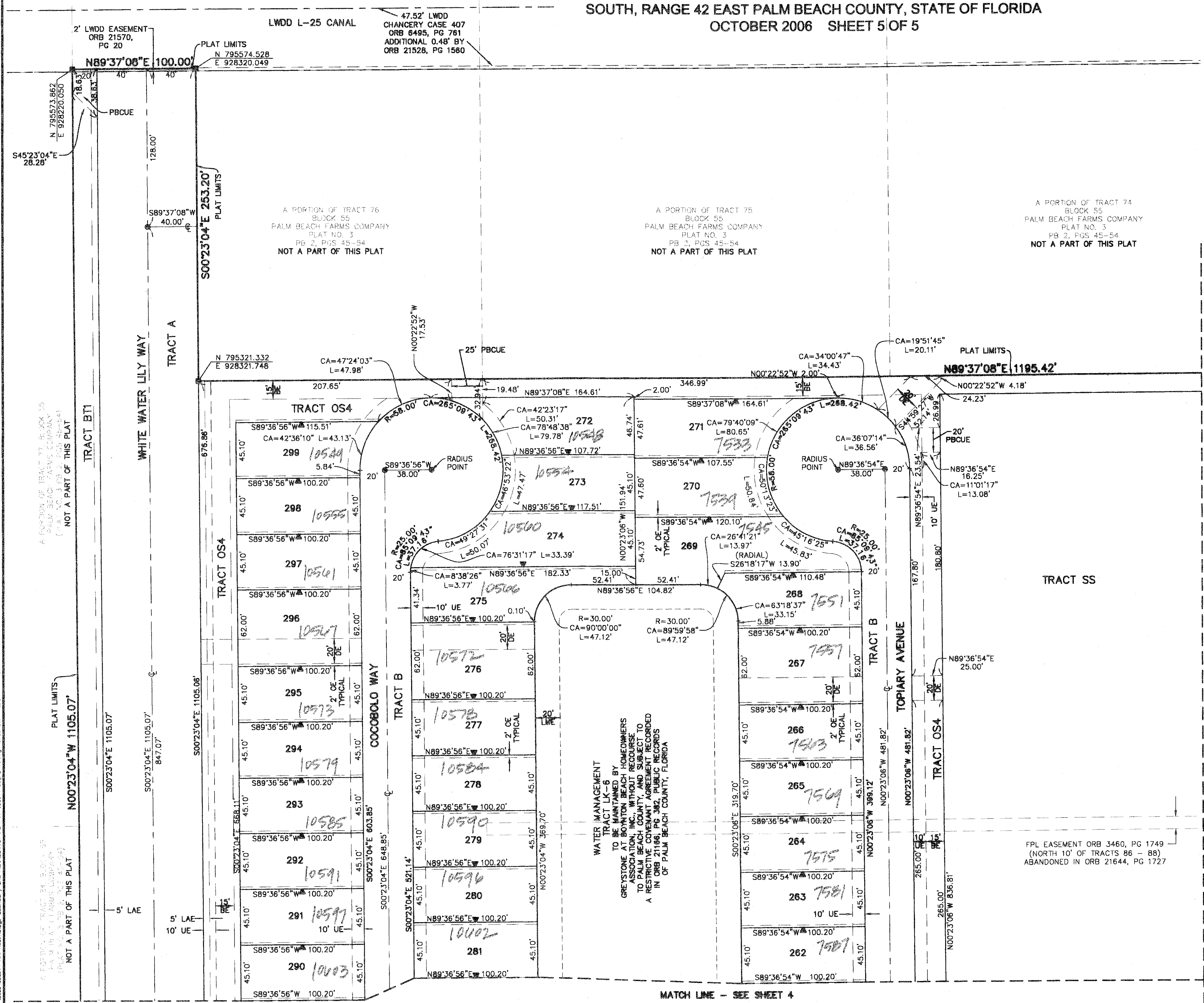

MATCH LINE - SEE SHEET 4

MATCH LINE - SEE SHEET 3

SUBDIVISION MINI ASSEMBLAGE P.L.B.
BOOK 110
FLOOD ZONE B
QUAD # 59
TAX 958
PUB NAME

REVISIONS: 04-20-07